

THE LEGENDARY
DOUGLAS DC-3

A PICTORIAL TRIBUTE



DAKOTA - GOONEY BIRD - SKYTRAIN - SPOOKY - SKYTROOPER

A PHOTOGRAPHIC TRIBUTE ACROSS THE GLOBE ON
THE ICONIC DOUGLAS DC-3 & C-47
'THE LEGEND GOES ON'



THE LEGENDARY DOUGLAS DC-3

A PICTORIAL TRIBUTE



MICHAEL S. PROPHET

Lanasta

Lanasta

ISBN: 9789464560640
e-ISBN: 9789464560657

NUGI: 465
1st print run, November 2022

© Copyright 2022
Walburg Pers / Lanasta

DTP: Jantinus Mulder
Photos: Michael Prophet
Proof read: Tony Merton Jones

All patches & stickers: M. Prophet Collection

Category:
Historic Transport Plane - Douglas, Dakota,
DC-3/C47, Super DC-3, Piston twin engine
propliner - Vintage transport.

Center Photo:
Mid America Flight Museum N5106X, Mount
Pleasant Texas

Printed in the Netherlands.

All rights reserved. Without limiting the rights under copyright reserved above, no part of this book may be reproduced, stored in or introduced into a retrieval system, or transmitted, in any form or by any means (electronic, mechanical, photocopying, recording or otherwise) without the written permission of both the copyright owner and the author of the book.

Every effort has been made to obtain permission to use all copyrighted illustrations reproduced in this book. Nonetheless, whosoever believes to have rights to this material is advised to contact the publisher.

All correspondence regarding copyrights, translation or any other matter can be directed to:

Walburg Pers / Lanasta,
Nieuwe Prinsengracht 89,
1018VR Amsterdam

www.lanasta.com



FOREWORD

It gives me great pleasure to introduce a book written and compiled by one of the world's most talented and dedicated aviation photographers. For many years I have been impressed by Michael's intense passion for the Douglas DC-3, and in his quest to shoot the aircraft in as many locations around the world as possible he has become one of the leading authorities on the type. His countless contributions to "Propliner" over the years have helped to create a loyal readership all over the world and here is an opportunity to enjoy even more of his magical photographs.

Surely one of the world's most iconic aircraft, the Douglas DC-3 has captivated enthusiasts for generations. More than eighty years after her maiden flight, the type is still making history today, and the recent round-the-world flight by a 1939-vintage example is surely testimony to the robust nature of the aircraft's design and its enduring popularity.

Originally purchased by American Airlines as the Douglas Sleeper Transport, the airliner soon evolved into the DC-3 that we know and love today. By the time that war broke out in 1939, DC-3s were in service with many other American airlines including United, Eastern and Braniff, while across the Atlantic in Europe the DC-3 had instant appeal, with KLM, SABENA, Sweden's ABA, Swissair and others all acquiring the revolutionary new airliner. Of course, the war changed everything, and overnight the DC-3 found an important new role as military transport. Serving in large numbers with the Allies, the aircraft became known as the Dakota, C-47 'Skytrain' or 'Gooney Bird', and this versatile flying machine became the backbone of the transport force. It took part in many famous operations, the most notable of which was the Allied invasion of northern France, when on D-Day - June 6 1944 - a grand total of 821 Skytrains and Dakotas dropped 13,000 paratroops over enemy lines. There were many other occasions when the aircraft flew her way into the history books, but none was as poignant or memorable as the D-Day operation.

Post-war the DC-3 helped to restore many vital air services around the world, as the arrival of peace and the need to establish aerial communications between countries as quickly as possible ensured that the DC-3 was given this task until new airliners became available. Although many designs were marketed as a 'DC-3 replacement', it took several decades before the type was replaced in airline service, while air forces around the world continued to take full advantage of this rugged transport for many years. Indeed, the type was so popular that turboprop conversions still fly today with numerous air forces across the globe.

Everyone must have their own special DC-3 memory, and for me it was my first ever flight in a DC-3 nearly fifty years ago. It was a sunny August afternoon and during a stroll through the terminal at East Midlands Airport I came upon a rather scruffy individual in an old green sweater selling tickets for a pleasure flight aboard Kestrel Aviation's former BEA "Pionair" G-AMFV. Seizing the opportunity, a ticket was promptly purchased and minutes later a small group of passengers was led out to the aircraft parked on the main apron alongside many more modern jet and turboprop types. Having taken our seats in the cabin, I was amazed to see the green jersey-attired ticket seller making his way up to the cockpit, where he duly took his place in the captain's seat and proceeded to convey his clients on the most enjoyable of pleasure flights ever. Our twenty-minute aerial excursion over the Derbyshire countryside preceded a landing in the wake of a British Midland BAC One-Eleven jet arriving from Jersey - a routine daily adventure for the DC-3 just a few years earlier.

As you thumb your way through this book please imagine the effort that has gone into the creation of each and every picture, and the pleasure that it has given the photographer.

Tony Merton Jones
Editor - Propliner
Salisbury January 2022



ABOUT THE AUTHOR



From a young age, Michael S. Prophet became fascinated with aviation, when he started drawing WW2 airplanes at primary school. Born on the Caribbean Island of Curacao, Dutch Antilles (1956), his first introduction off flying was when, as a baby his mother took him for a family visit to Trinidad, Tobago onboard a twin engine KLM Convair 440.

After moving to The Netherlands with his parents, his love for aviation really kicked off when he purchased his first transatlantic ticket with Pan Am, flying on a Boeing 707 jetliner visiting friends in New York in 1974. This also triggered the interest in taking photographs. Since then much of his spare time, has been devoted to aviation/travel and photography.

Just out of high school, he started his career at KLM Royal Dutch Airlines as a junior aircraft mechanic, working on Douglas DC-8 and B747/DC-10 wide-bodies Jumbo Jets. Later he started working at Dutch Fokker Aircraft Company, where he worked as an Interior Design Engineer on several new projects, such as the all new twin engine Fokker 50 and F100 jetliner.

In the early 1980s he bought a copy of the famous Osprey Colour Series 'Skytruck' book. The author Stephen Piercy, became

like a mentor and inspiration to him. Admiring the amazing pictures he quickly developed his own style of photography. This was the moment that he started a life-long love for the dwindling number of classic jet & prop-liners around the globe.

Whilst on holiday in Hawaii, he photographed his first real operational Douglas DC-3 at Honolulu airport and a couple of years later, on the other side of the world, he got his first passenger ride on the vintage Douglas DC-3, onboard an Aero Virgin Island Airways flight from San Juan PR to St Thomas Virgin Islands ... and the rest is history as they say!

DEDICATION:

I am dedicating this book to my beloved mother "*Ena Yasmini Alexander*" (2018†) and younger brother "*Stuart Heston Schmidt*" (2020†), they both passed suddenly and way too soon. My mother's legacy sparked the interest in me for my global travels and photography.

website: Vintage Aviation Pictures - www.michaelprophet.com



Top:

The author at work, doing what he loves best, taking pictures of a DC-3. Hill Air Co, Fort Lauderdale Florida 1987

Photo: Paul van den Berg

CONTENTS



5	FOREWORD
6	ABOUT THE AUTHOR
9	DEVELOPMENT HISTORY
13	DOUGLAS DC-2
15	DOUGLAS DC-3 / C-47
35	D-DAY SQUADRON
55	WRECKS AND RELICS
65	MUSEUMS
79	CANADA
89	USA
133	SOUTH AFRICA
139	SOUTH AMERICA
165	AIRSHOWS EUROPE
171	AIRSHOWS USA
176	THE LEGEND AT NIGHT'
179	FLYING DC-3S IN ALL VARIANTS
180	INDEX

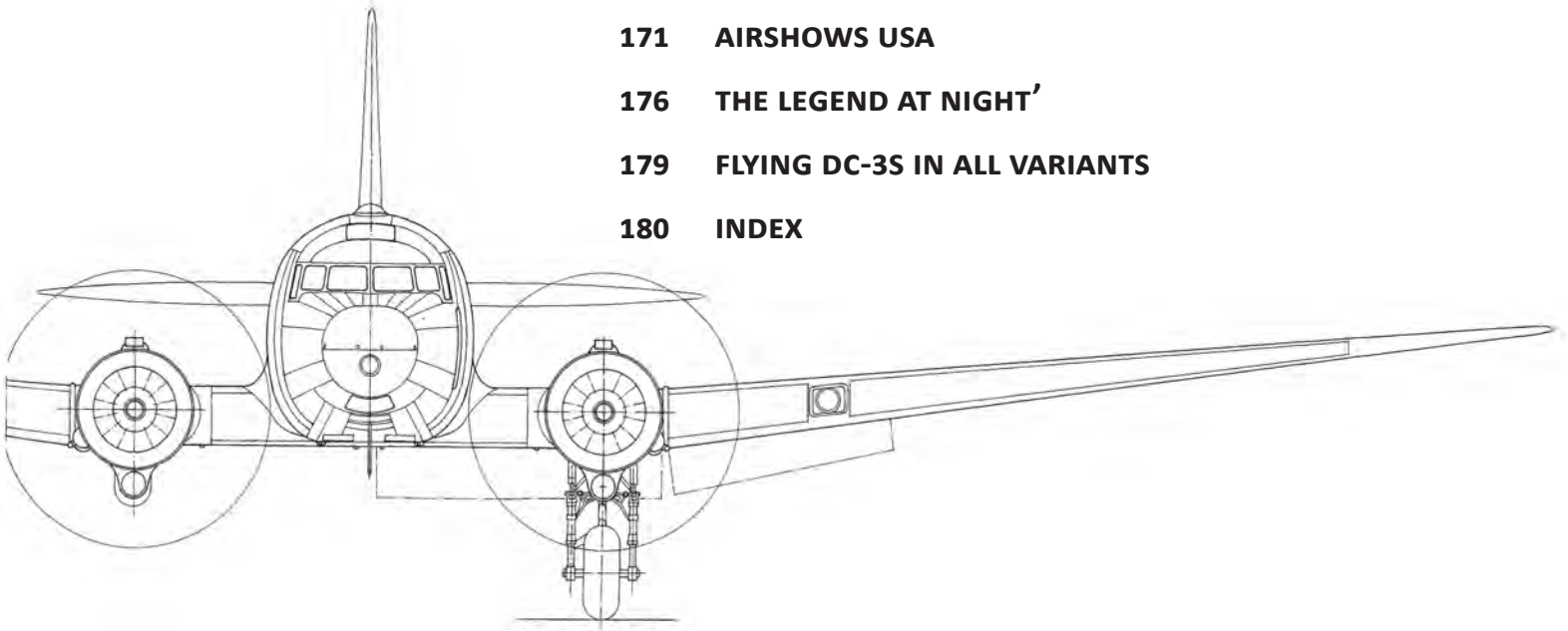

2ND DISCLAIMER

To the best of my knowledge the information in this book is true and complete. All data & information quoted are without any guarantee on the part of the author & publisher, who also disclaims any liability incurred in connection with use of this data or specific detail. We recognize that some words, model names and designations are the property of the trademark holder. This is used only for identification purposes.

BIBLIOGRAPHY/REFERENCE/SOURCE:

- *The Douglas DC-1/DC-2/DC-3, The First Seventy Years* Jennifer M. Gradidge Air Britain (2006) & *75 Years "Celebration Edition 3"* (2011)
- *The Legacy of the DC-3* - by Henry M Holden (1996) Wind Canyon Publishing Inc
- *DC-3 & C-47 Gooney Birds* by Michael O'Leary Motorbooks International (1992)
- *Skytruck* by Stephen Piercey Osprey Publishing Limited (1984)
- *Naval Fighter Series Douglas R4D-8/C-117D Super Gooney* by Steve Ginter (2013)
- *The Legendary DC-3* by Carroll V Glines and Wedell F Moseley - Bantam Air Series (1979)
- *Douglas - The Santa Monica Years* Marquand Books (2009)
- D-Day Squadron USA - Tunison Foundation
- Aviation Safety Network ASN
- Private files, travel notes & aircraft spotting logs
- Jan Koppen, Andre van Loon, Paul van den Berg plus many international aviation friends who provided input, technical support and relevant information.



DEVELOPMENT HISTORY

THE WINGS OF HISTORY

This magnificent aircraft has earned its place in aviation history, set many records and scored innumerable aviation firsts! It has flown more miles, piled up more flying time, carried more cargo and passengers than any other airplane in the world. It helped to lift America out of the depression and helped to make civilian Air Transportation to flourish across the globe. Its manufacture called it Douglas Commercial 3 (DC-3). It has many names such as: "Dizzy Three", "Old Methuselah", "Placid Plodder", "Dowager Duchess" and "Gooney Bird". The US Air Force called it "Skytrain" or "Skytrooper". The US Navy referred to it as a "R4D" and while in use as an AC-47 in Vietnam conflict it was referred to as "Spooky" or "Puff the Magic dragon". The British called it the "Dakota". During the Berlin Airlift she was referred to as "Rosinbomber" as known as "Candy Bomber".

US PRODUCTION

It was clear that the Douglas Santa Monica plant, from which all DC-2s and early model DC-3s were manufactured, would not be able to meet the new delivery schedules and the increased production for US Government and later the WW2 effort. It was decided a new plant at Long Beach California was to be constructed. The first C-47-DL came off this line at the end of December 1941. A 3rd production line at Oklahoma City was set up and was used only for the production of C-47-DK "SKYTRAINS" and C-117-DK.

- DO** Santa Monica production,
- DL** Long Beach production
- DK** Oklahoma production



Typical civil designation: DC-3A

- DC-3 = Douglas Commercial 3
- A = production model/engine variant

Typical early model designation: DST-A-207A

- DST = Douglas Sleeper Transport

Typical early model designation: DC-3-202A

- 202A = customer model

Typical military designation: C-47A-60-DL

- C-47 = military version of the DC-3
- A = production model
- 60 = USAF Block Number
- DL = production plant



RUSSIAN PRODUCTION

The USSR bought 21 DC-3s direct from Douglas, through various trading companies between 1936 and 1939. At least two of these were delivered unassembled to serve as patterns for licence production. Production was initially undertaken at the State Aircraft Plant No 84 near Moscow and started in 1940. The first aircrafts were designated as PS-84 (Passazhirskii Samolet – Plant 84) and they were fitted with the 900 hp Shvetsov M-62 engines. Later in 1941 the production plant was forced to move to the Tashkent Plant no 18 and the aircraft designation was changed into Lisunov Li-2.

JAPANESE PRODUCTION

When the DC-2 was launched, Japan was looking for a replacement for their outdated Fokker Super Universal and Trimotor fleet. In March 1934 Nakajima Hikoki KK bought the licence right to build and sell the DC-2 in Japan. A single complete DC-2 was delivered during November 1934. Several DC-2s were delivered, but the DC-3 showed greater promise and that ended the DC-2 production. Mitsui purchased the production rights for the DC-3 in February

1938. The first aircraft assembled from American components emerged in September 1939 for Japan Air Transport Co. but the 2nd and 5th aircraft went to the Navy! The imported DC-3s were known as D1 and the Japanese production line labelled them D2...later L2D. The Allies used the nickname "Tabby". The L2D were fitted with 1000 hp Mitsubishi Kinsei 43 engines.

Production Figures (Air Britain DC-1, DC-2, DC-3 the First Seventy Years 2006)	
Santa Monica Civil DC-3	579
Santa Monica Military	382 (C-41, C-41A, C-53, C-53D and R4D-2)
Long Beach Military	4285 (C-47, C-47A, C-47B and R4D-1)
Oklahoma City Military	5381 (C-47A, C-47B, C-117A and R4Ds)
Oklahoma City Civil DC-3D	28
Grand Total	10,655
Japanese L2D	487
Russian Li-2	4937
World Total	16,079

Note: During the hectic years of World War II, no less than 268 DC-3s (134 built at Long Beach and 134 at Oklahoma) were issued identical construction numbers (c/n). This error resulted in 134 pairs of DC-3s that had the same c/n, but were in fact different aircraft.

This situation was officially corrected by Douglas in a Service Bulletin in July 1946. In this bulletin, Douglas determined that the c/n as allocated by the Long Beach plant were correct (and thus remained unchanged), and the c/n as allocated by the Oklahoma plant were revised. The corrected c/n are usually written as 13798/25243, i.e. incorrect number first, new number last.

Page left

Spirit of Santa Monica Douglas C-53D
Santa Monica Airport California

AIRFRAME MODIFICATIONS

Various modifications of existing airframes have been made either experimentally or for commercial use, by fitting non-standard engines and numerous other technical changes. This is a brief listing of major modifications.

Hi-Per DC-3

Modified by Pan American for use by Panagra and Avianca, with 1450 hp P&W R-2000-D5 engines & various airframe modifications to improve single-engined performance Also Known as a model DC 3-R2000

Mamba Dakota

Test-bed used for Armstrong Siddeley and fitted with 1425 hp Mamba ASMa.3 engines and later with the more powerful 1590 hp Mamba ASMa.6.

Dart-Dakota (1)

Test-bed modified by Rolls-Royce with 1540 hp Dart 504 engines and later with 1640 hp Dart 510 & 526 (one in each nacelle)

Dart-Dakota (2)

Modified by Field Aircraft Services for BEA trials before the Viscount deliveries and fitted with 1540 hp Dart 505s engines. (max weight: 28,200 lbs - 12,900 kg)

Abbreviations:	
c/n	construction number
s/n	serial number
a/c	aircraft
AF	Air Force
BuNo	Bureau Number
Aka	Also known as
STC	Structural Type Certificate
CAA	Civil Aviation Authority
CAA	Chinese Aviation Authority
Max	Maximum
MK	Mark
Hp	Horsepower
WW2	World War 2
RAF	Royal Air Force
LLC	Limited Liability Company
LH	Left Hand
RH	Right Hand
USN	United States Navy
USMC	United States Marine Corps
Ltd	Limited
Corp	Corporation
VIP	Very Important Person
USAAF	United States Army Air Force

Dart-R4D-8

Rolls-Royce Darts were fitted to N156WC for Pilgrim Airlines

USAC DC-3 Turbo Express

Aircraft fitted with PT-6A-45R engines and various airframe modifications such as square-tips tail-plane, new generators, electric, fuel, hydraulic and fire protection changes.

Basler BT-67

When Basler took over the Turbo Express DC-3 additional modifications were made. New 1424 hp PT-6A-67R engines were fitted giving the aircraft a payload of 13,000 lb. It was marketed as Basler Turbo-67 (BT-67) with a new STC February 1990.

Airtech

Modification consisted of replacing the R-1830s with WSK ASz-621Rs a variant of the Wright Cyclone R-1820 radial engine

AMI DC-3-65TP

Schafer Aircraft Modification Inc in conjunction with Aero Mod International (AMI) developed a turboprop conversion using the Pratt & Whitney Canada PT6A - 65AR engines. It was marketed as Schafer DC-3-65TP Cargo-master (1985). Kansas based Dodson International took over the AMI Supplemental Type Certificate (STC) and started DC-3 conversion (1997). Then in 2016 the

AMI STC was re-sold to Preferred Airparts LLC based at Kidron (OH) and remarketing it as the Preferred Turbine -3.

BSAS DC-3/C-47-65ARTP Aircraft

Turboprop conversion by BSAS International based at Wonderboom Airport South Africa. Based on a Wonder Air PTY Ltd modification STC for civilian and military use

Tri-Turbo-Three

The Tri-Turbo-Three (N4700C/N23SA) was a one-off conversion which reappeared in 1977. It's the only triple engined DC-3 which was fitted with the Pratt & Whitney PT-6A engines. The concept by Jack Conroy and Clay Lacy was first flown in 1977. It was marketed by Specialised Aircraft, Camarillo CA but never received a FAA certificate.

TS-62 = a hybrid soviet C-47B conversion

which included the ASH-62IR radial engines and extra LH side cockpit window. They were used by Aeroflot until 1957. Some were sold to china.

Canadair

Along with a large Douglas equipment stock, Canadair also purchased a large number of former USAAF C-47 Skytrains, as well as ex-Royal Air Force (RAF) Dakota transports. From 1945 to 1947, Canadair converted, modified, overhauled, and re-built several hundreds of C-47/DC-3 conversions for numerous domestic and international air carriers.

Scottish Aviation limited

The Scottish Aviation Dakota conversions where authorised by the Douglas Repair, Overhaul and Conversion centre for Great Britain. They could convert any DC-3 into four categories: regular freighters, standard 21 seater airlines configuration and Deluxe 21 seater and a VIP executive model.

Tropicana DC-3 (1957)

The Tropicana Conversion was designed, engineered and produced by L.B. Smith Air Corp based at Miami. This conversion consisted of replacing the forward cabin bulk-head with plexiglas panels. This created extra space and thus allowing extra forward windows. Extra side mounted divans and swivel chairs were fitted. In addition the more

powerful Wright engines were installed increasing the cruising speed to 210 miles per hour.

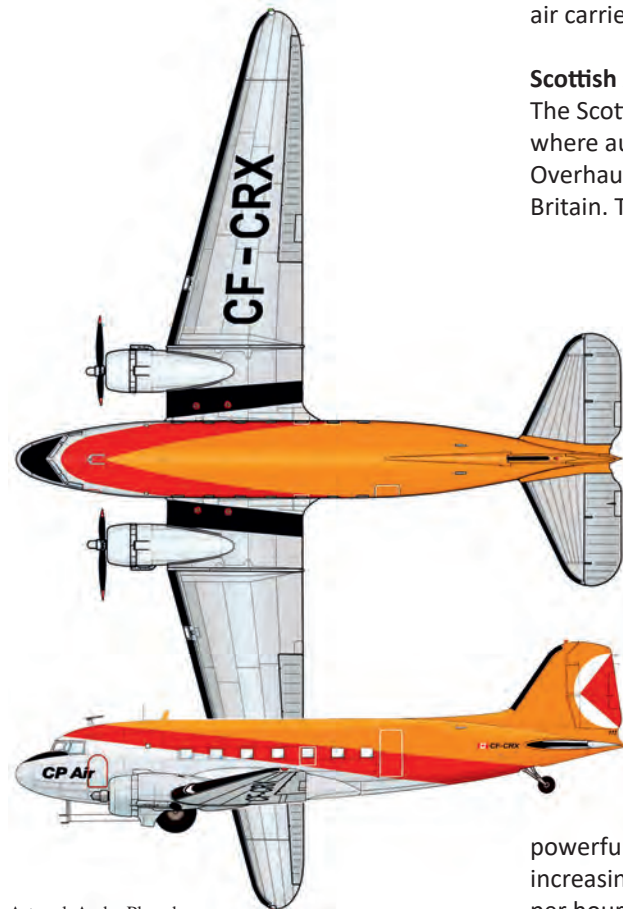

Artwork Andre Plourde



DOUGLAS AIRCRAFT COMPANY, SANTA MONICA CALIFORNIA, THE BIRTHPLACE OF THE DC-3

Douglas C-53-DO N242SM (c/n 4877) was originally delivered as a C-53 "Skytrooper" but converted to a US Navy R4D-3 with BuNo 05075 February 1942. Its initial role was a 28-seat paratrooper and glider tug aircraft. Retired from military service she was purchased by Nationwide Airlines with registration NC1075M August 1946.

This aircraft was been refitted with a AiResearch Maximizer kit, which included landing gear doors, short engine exhaust stacks, special engine cowling, oil cooler fairings and a large dome prop spinner. According to the AiResearch brochure this kit added a 20 mph speed increase and 200 miles range.

Painted in bold blue & red colors with Douglas "Spirit of Santa Monica" title's she is displayed at the Santa Monica Airport, CA and pays tribute to the company's founder "Donald Wills Douglas" and the historic nature of this airport. The first flight of a DC-3 took place on December 17, 1935 at the Santa Monica Airport. These aircraft were so successful and reliable that countless DC-3 aircraft followed in production and remain in service throughout the world today. May 2017

Note: The city of Santa Monica and the Douglas Aircraft Company are tied together in aviation history. Over 10,724 airplanes were produced ranging from the 1921 Cloudster to the B-18 Bolo, A-29 Havoc, DC-1, DC-2, DC-3, DC-4, DC-6 and the last piston airliner DC-7. The DC-3 monument is located at 3100 Airport Ave on the South side of the airport. Surrounding the aircraft are landscaped walkways, benches and a bronze sculpture of Donald Wills Douglas and his dog Bar.

